



INSTRUCTIONS FOR 100A 230V MMA/TIG Inverter Welder

Stock No.83402 Part No.INV106

IMPORTANT: PLEASE READ THESE INSTRUCTIONS CAREFULLY TO ENSURE THE SAFE AND EFFECTIVE USE OF THIS PRODUCT.



GENERAL INFORMATION

These instructions accompanying the product are the original instructions. This document is part of the product, keep it for the life of the product passing it on to any subsequent holder of the product. Read all these instructions before assembling, operating or maintaining this product.

This manual has been compiled by Draper Tools describing the purpose for which the product has been designed, and contains all the necessary information to ensure its correct and safe use. By following all the general safety instructions contained in this manual, it will ensure both product and operator safety, together with longer life of the product itself.

All photographs and drawings in this manual are supplied by Draper Tools to help illustrate the operation of the product. Whilst every effort has been made to ensure the accuracy of information contained in this manual, the Draper Tools policy of continuous improvement determines the right to make modifications without prior warning.

1. TITLE PAGE

1.1 INTRODUCTION:

USER MANUAL FOR:

100A 230V MMA/TIG INVERTER WELDER

Stock no. 83402.

Part no. INV106.

1.2 REVISIONS:

Date first published October 2015

As our user manuals are continually updated, users should make sure that they use the very latest version.

Downloads are available from: <http://www.drapertools.com/manuals>

DRAPER TOOLS LIMITED

HURSLEY ROAD

CHANDLER'S FORD

EASTLEIGH

HAMPSHIRE

SO53 1YF

UK

WEBSITE:

draper.co.uk

PRODUCT HELPLINE:

+44 (0) 23 8049 4344

GENERAL FAX:

+44 (0) 23 8026 0784

1.3 UNDERSTANDING THIS MANUALS SAFETY CONTENT:

WARNING! Information that draws attention to the risk of injury or death.

CAUTION! Information that draws attention to the risk of damage to the product or surroundings.

1.4 COPYRIGHT © NOTICE:

Copyright © Draper Tools Limited.

Permission is granted to reproduce this publication for personal & educational use only.

Commercial copying, redistribution, hiring or lending is prohibited.

No part of this publication may be stored in a retrieval system or transmitted in any other form or means without written permission from Draper Tools Limited.

In all cases this copyright notice must remain intact.

2. CONTENTS

2.1 CONTENTS

<i>Page content</i>		<i>Page</i>
1	TITLE PAGE	
	1.1 INTRODUCTION	2
	1.2 REVISION HISTORY	2
	1.3 UNDERSTANDING THIS MANUAL	2
	1.4 COPYRIGHT NOTICE	2
2	CONTENTS	
	2.1 CONTENTS	3
3	GUARANTEE	
	3.1 GUARANTEE	4
4	INTRODUCTION	
	4.1 SCOPE	5
	4.2 SPECIFICATION	5
	4.3 HANDLING & STORAGE	5
5	HEALTH & SAFETY INFORMATION	
	5.1 GENERAL SAFETY INSTRUCTIONS FOR WELDING	6
	5.2 CONNECTION TO THE POWER SUPPLY	6
6	TECHNICAL DESCRIPTION	
	6.1 IDENTIFICATION	7
	6.2 MAIN COMPONENT DESCRIPTIONS	8
7	UNPACKING & CHECKING	
	7.1 PACKAGING	9
	7.2 WHAT'S IN THE BOX?	9
8	SETTING THE MACHINE	
	8.1 AMPERAGE	10
9	PREPARING THE WELDER	
	9.1 INSTALLATION	11
10	MAINTENANCE	
	10.1 GENERAL MAINTENANCE	12
11	EXPLANATION OF SYMBOLS	
	11.1 EXPLANATION OF SYMBOLS	13
12	DISPOSAL	
	12.1 DISPOSAL	14
	DECLARATION OF CONFORMITY	ENCLOSED

3. GUARANTEE

3.1 GUARANTEE

Draper tools have been carefully tested and inspected before shipment and are guaranteed to be free from defective materials and workmanship.

Should the tool develop a fault, please return the complete tool to your nearest distributor or contact Draper Tools Limited, Chandler's Ford, Eastleigh, Hampshire, SO53 1YF. England. Telephone Sales Desk: (023) 8049 4333 or Product Helpline (023) 8049 4344.

A proof of purchase must be provided with the tool.

If upon inspection it is found that the fault occurring is due to defective materials or workmanship, repairs will be carried out free of charge. This guarantee period covering parts/labour is 12 months from the date of purchase except where tools are hired out when the guarantee period is ninety days from the date of purchase. The guarantee is extended to 24 months for parts only. This guarantee does not apply to normal wear and tear, nor does it cover any damage caused by misuse, careless or unsafe handling, alterations, accidents, or repairs attempted or made by any personnel other than the authorised Draper warranty repair agent.

Note: If the tool is found not to be within the terms of warranty, repairs and carriage charges will be quoted and made accordingly.

This guarantee applies in lieu of any other guarantee expressed or implied and variations of its terms are not authorised.

Your Draper guarantee is not effective unless you can produce upon request a dated receipt or invoice to verify your proof of purchase within the guarantee period.

Please note that this guarantee is an additional benefit and does not affect your statutory rights.

Draper Tools Limited.

4. INTRODUCTION

4.1 SCOPE

This machine is designed for welding ferrous metals during light fabrication processes.

4.2 SPECIFICATION

Stock no	83402
Part no	INV106
Motor:	
Rated voltage	230V~
Rated frequency	50Hz
No load voltage	56V
Welding current	10-100A DC
Rated duty cycle	60%@100A
Usable electrodes	1.6-2.5mm
Ingress protection rating	IP21S
Insulation class	F
External dimensions	345x130x245mm
Weight	3.2kg

4.3 HANDLING & STORAGE

This machine should be stored in a dry location and in its box. Avoid storing this machine in areas prone to damp or humidity.

When handling this machine never pick up or carry this machine by the electrode holder, earth clamp or power supply cable. Always use the carry strap provided.

5. HEALTH & SAFETY INFORMATION

5.1 GENERAL SAFETY INSTRUCTIONS FOR WELDING

Always wear suitable protective clothing when welding. You are advised to use an approved welding helmet, leather apron, welding gauntlets and an approved welding mask as the bare minimum safety equipment for welding.

Always perform welding in a well ventilated area or use suitable fume extraction apparatus. Cover any exposed skin whilst welding as burns can occur due to spatter, hot flux and ultra violet radiation produced during the welding process.

All welding fumes are hazardous to health, appropriate respiratory protection must be used at all times whilst welding fumes are present.

Ensure that there are no flammable/combustible materials or fluids/gases in the area where you will be welding.

5.2 CONNECTION TO THE POWER SUPPLY

Make sure the power supply information on the machine's rating plate are compatible with the power supply you intend to connect it to.

This machine is fitted with a 13A 3pin plug. It is designed for connection to a power supply rated at 230V AC.

Because it is constructed mostly of metal parts, it is a Class 1 machine; meaning, it must have an earth connection in the power supply. This is to prevent electrocution in the event of a failure.

6. TECHNICAL DESCRIPTION

6.1 IDENTIFICATION



- ① Electrode holder connection
- ② Earth clamp connection
- ③ Indicator lamps
- ④ Amperage control
- ⑤ Inverter MMA welder

- ⑥ Carry handle
- ⑦ Power switch
- ⑧ Power supply cable and plug
- ⑨ Earth clamp
- ⑩ Electrode holder

6. TECHNICAL DESCRIPTION

6.2 MAIN COMPONENT DESCRIPTIONS

Amperage control

This rotary dial is used to adjust the welding current.

Indicator lights

There are two indicator lights fitted to the front fascia on the welding machine.

The upper indicator light illuminates to indicate that the machine is switched on and receiving mains power.



The lower indicator light marked will illuminate if the machine duty cycle is exceeded.



If this indicator light illuminates the machine must be allowed to cool before welding can resume.

Electrode holder

This is used to hold the welding electrode during welding. Press the thumb lever to insert, release the electrode.

Earth clamp

This must be fixed to the workpiece to be welded to complete the welding circuit. Ensure that the earth clamp is attached to a clean, non rusted and non painted area of the workpiece.

7. UNPACKING & CHECKING

7.1 PACKAGING

Carefully remove the machine from the packaging and examine it for any sign of damage that may have happened during shipping. Lay the contents out and check them against the parts shown below. If any part is damaged or missing; please contact the Draper Helpline (the telephone number appears on the Title page) and do not attempt to use the machine.

The packaging material should be retained at least during the guarantee period: in case the machine needs to be returned for repair.

Warning! Some of the packaging materials used may be harmful to children. Do not leave any of these materials in the reach of children.

If any of the packaging is to be thrown away, make sure they are disposed of correctly; according to local regulations.

7.2 WHAT'S IN THE BOX?

As well as the welder; there are several parts not fitted or attached to it.

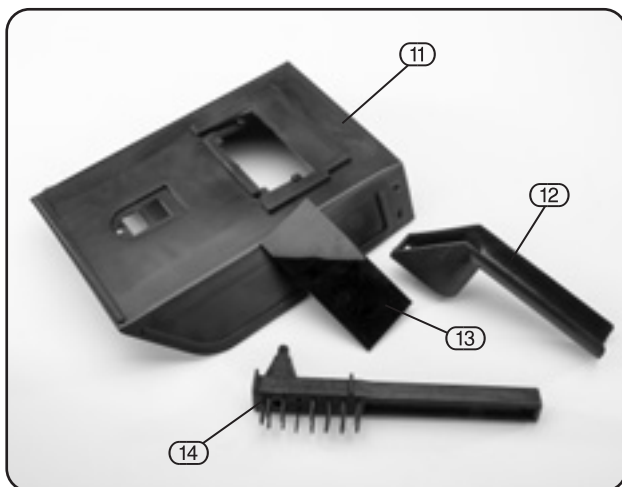

- ① Face shield.
- ② Face shield handle.
- ③ Face shield welding filter glass.
- ④ Welding brush.

8. SETTING THE MACHINE

8.1 AMPERAGE

Once you have set up your machine as described in section 8 (preparing the welder) you are ready to start welding. The size of your chosen electrode will determine what welding current will be required.

Below is a general guide to electrode size and current requirements.

ELECTRODE SIZE	1.6MM	2.0MM	2.5MM	3.0MM	3.2MM
AMPS REQUIRED	40	55	80	100	140

Using the above table as a guide set the machines current to that shown above for your chosen size of welding electrode. Strike an arc by swiping the top of the electrode against the workpiece, if the arc does not strike tap the tip of the electrode against the work piece, once the arc is struck proceed to weld as normal.

9. PREPARING THE WELDER

9.1 INSTALLATION

Prior to assembling the machine it is important to ensure that the included welding face shield is assembled and ready for use. Take the welding face shield handle (12) slide the handle upwards so that the circular protrusion locates into the circular hole on the face shield.

Finally slide the glass welding filter (13) into its holder ensuring that it fills its holder with no gap that could allow flash to pass through.

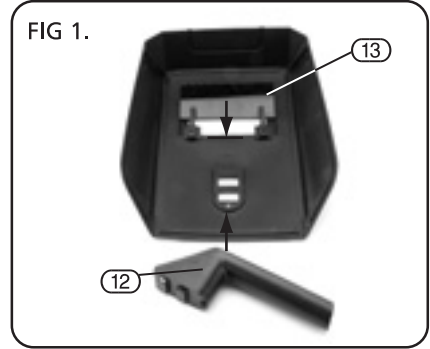

This machine is fitted with a 13A plug. Before first use ensure that you are familiar with the machines designed usage and features, ensuring that you fully understand all of the machines controls. Once you are satisfied that you fully understand the machine attach the earth clamp and electrode holder to the machine taking notice of the correct polarity. Next connect the earth clamp to the workpiece to be welded ensuring a good electrical contact (clean non rusted and non painted surface). You are now ready to select your chosen electrode type (dependant on the material to be welded) and fix the electrode into the electrode holder by pressing on the thumb lever to open the clamp. Place the bare end of the electrode between the two clamping pieces of the electrode holder ensuring that it is located in one of the grooves that offers you the most suitable angle for welding. Release the thumb lever to clamp the electrode in place. You are now ready to plug the machine into the mains power and turn it on.

Warning!

Whilst the machine is turned on keep the electrode away from any metal that is connected either directly or in directly to the earth clamp. Sudden arcing can result from careless electrode placement.

10. MAINTENANCE

10.1 General Maintenance

This machine contains no user serviceable parts.

To maintain this machine in full working condition for the duration of its useful life you must inspect all wires/cables on this machine for wear and/or damage and immediately replace any worn or damaged cables.

This machine should be stored in a dry location that is not subject to damp/dust or extremes of temperature. Keep the external of this machine and all cables clean by wiping down with a clean cloth.

11. EXPLANATION OF SYMBOLS

11.1 EXPLANATION OF SYMBOLS



Warning!
General warning



Warning!
Welding arc eye protection
required



Warning!
Read the instruction
manual



Warning!
Welding fumes may cause irritation
of the eyes, nose and throat.



WEEE
Do not dispose of Waste Electrical
& Electronic Equipment in with
domestic rubbish

12. DISPOSAL

12.1 DISPOSAL

- At the end of the machine's working life, or when it can no longer be repaired, ensure that it is disposed of according to national regulations.
- Contact your local authority for details of collection schemes in your area.

In all circumstances:

- Do not dispose of power tools with domestic waste.
- Do not incinerate.
- Do not abandon in the environment.
- Do not dispose of WEEE* as unsorted municipal waste.



* Waste Electrical & Electronic Equipment.

- **DRAPER TOOLS LIMITED,**
Hursley Road, Chandler's Ford,
Eastleigh, Hampshire. SO53 1YF. U.K.
- **Helpline:** (023) 8049 4344
- **Sales Desk:** (023) 8049 4333
- **General Enquiries:** (023) 8026 6355
- **Service/Warranty Repair Agent**
For aftersales servicing or warranty repairs, please
contact the Draper Tools Helpline for details of an
agent in your local area.

YOUR DRAPER STOCKIST

KCKC0915

